



One Henkel Way
Rocky Hill, CT 06067
Technical Information Help Line 1-800-562-8483
www.equipment.loctite.com

Product Description Sheet

Loctite® VA10 Micro Diaphragm Valve
Part # 1611449

North American Engineering

PRODUCT DESCRIPTION

The Loctite® VA10 Micro Diaphragm Valve is a miniature dispensing valve designed to dispense precision drops and beads of low to medium viscosity adhesive. Its compact size allows for close center to center spacing for multiple point dispensing in applications like needle bonding. Its light weight allows for faster motion control movements when used on robot systems and can dispense at a faster frequency as compared to conventional valves. A tamper resistance stroke control provides for high resolution stroke adjustment which results in consistent flow control and bubble free, no drip dispensing.

PRODUCT FEATURES

- Bubble free, no drip dispensing
- Compact size and weight
- High resolution stroke adjustment
- Seal less design
- Fail safe – air to open, spring to close
- UHMW polyethylene diaphragm
- Fluid body material: 316 stainless steel
- Fitting - ¼" barbed type, 316 stainless steel
- Tamper resistance stroke control

TECHNICAL DATA

- Dimensions: 2.62 in [66.5 mm] length x 0.75 in [19 mm]
- Weight: 50 grams (1.76 oz)
- Diaphragm: UHMW polyethylene
- Air pressure required; 70 to 90 psi (4.8 to 6.2 bar)
- Maximum fluid pressure: 70 psi (4.8 bar)
- Fluid body: 316 stainless steel
- Air cylinder body: 303 stainless steel



Theory of Operation

The Loctite® VA10 Micro Diaphragm Valve is a normally closed, fail safe, adjustable opening diaphragm valve. Pressurized air is supplied to the air cylinder which acts on the internal piston and forces the diaphragm seal to a predetermine distance off the seat. This action allows pressurized adhesive to pass through the valve for given amount of time. This miniature pressure/ time dispense valve provides for high cycle rates and can be used for bead or drop applications.



One Henkel Way
Rocky Hill, CT 06067
Technical Information Help Line 1-800-562-8483
www.equipment.loctite.com

Product Description Sheet

Loctite® VA10 Micro Diaphragm Valve
Part # 1611449

North American Engineering

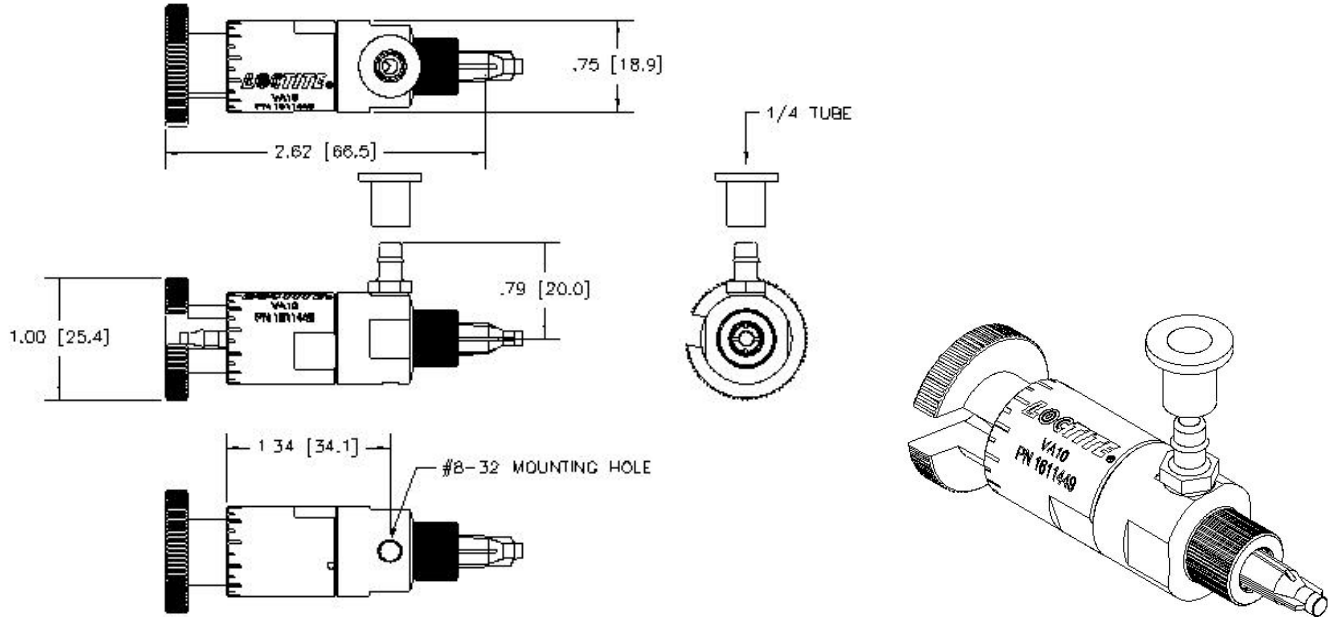

Loctite® VA10 Micro Diaphragm Valve includes:

- Operating Manual
- Feed line: 7 ft. [2 m] PTFE lined tubing, 1/4" [6.35 mm] O.D.
- Air line: 7 ft. [2 m] Polyurethane tubing, 5/32" [4 mm] O.D.
- Dispense Tip sample kit, 984127
- Stroke Control Adjustment Key
- Inlet fitting: #10-32 x 1/4" tube, barbed fitting, 316 stainless steel

Optional Accessories and System Components (sold separately):

- Loctite® Dual Channel Integrated Semi-Automatic Dispenser; 0 to 15 psi: # 1390322; 0 to 100 psi: # 1390321
- Loctite® Bond-A-Matic 3000 Reservoir, 0 to 15 psi : # 982726 w/o low level sensor; # 982720 w/ DC low level sensor
- Loctite® Bond-A-Matic 3000 Reservoir, 0 to 100 psi : # 982727 w/o low level sensor; # 982723 w/ DC low level sensor
- Loctite® Digital Dispense Controller; 97101

Recommended Spare Parts / Accessories

- Valve mounting block & screw PN 1638885
- Tamper Resistant Stroke Control Key PN 1638884
- Valve Rebuild Kit PN 1638886
- Valve Replacement Diaphragm, 5 Pack PN 1693581
- Feed line tubing, 1/4 inch [6.4 mm] O.D. black polyethylene, PTFE lined, 33 foot [10 m] length, item # 97972